

Technical Note

INTEGRATING AMAG TECHNOLOGY'S SYMMETRY ACCESS CONTROL WITH TAGMASTER XT RFID READERS



Technical Note

Integrating AMAG Technology's Symmetry Access Control with TagMaster XT RFID readers

INTRODUCTION

This document describes an advanced installation, in which the Symmetry Access Control System is integrated with a TagMaster System for Automatic Vehicle Identification (AVI) to control a gate/barrier when entering or exiting a parking location (i.e. garage, lot, or other premises).

Installation is intended to be completed by a qualified service technician. They should be comfortable and familiar with the installation concepts of the Symmetry Access Control System, and the TagMaster XT long-range RFID readers.

PROBLEM DESCRIPTION

The customer has a gated parking garage that they wish to control from their corporate AMAG Access Control System. The business has vehicles which enter the garage frequently, and those vehicles will be equipped with long-range TagMaster ID-tags.

SOLUTION

Using TagMaster RFID XT readers, tagged vehicles gain fast and convenient parking garage access, completely hands-free, without causing the driver to stop, open the window of the car, fumble to search for the card and position the card in a specific direction relative to the reader. This reduces wait times at the gate to promote optimal traffic flow, protects the driver from the weather elements, and increases comfort and safety. The TagMaster XT long-range reader has a read-range capability of up to 8 m.

The Symmetry Access Control will verify that the approaching vehicle has access to a location and allow/deny the vehicle to enter via a gate/barrier relay.

AMAG's Symmetry Panel

CORE COMPONENT REQUIREMENTS

- TagMaster XT readers.
- TagMaster ID tags for long-range reading.
- TagMaster Universal Mounting bracket.
- AMAG Access Control
- Power Supply



DATA COMMUNICATION CONFIGURATION

The data being transmitted between the TagMaster XT readers and the Symmetry Software should be configured to meet these criteria:

- To access the reader - set the reader to a fix IP address with dip-switch S101:3 ON the default IP address is 169.254.1.1.
- The TagMaster Wiegand connection is set to Data0, Data1 and GND, the dip-switch S301:6&7 shall be ON to use the pull-up resistors.
- It is possible to use LED control by connecting green and red LED to input 1 and 2.
- The reader supply DC voltage from 12-24 DC voltage

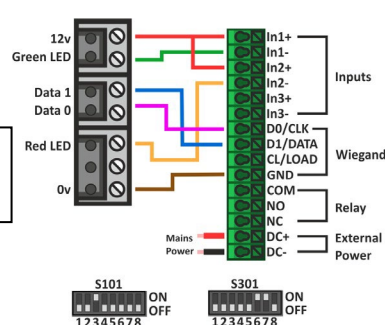

TagMaster's XT readers

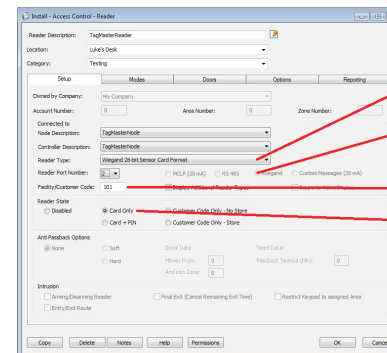

- Needs to be the same wiegand format as configured in the TagMaster reader
- Needs to be set to switch the reader into wiegand mode
- If using a format with no facility code, the transaction will use this code by default.
- Must be set to card only

The available security settings are:

SecureMarkID is TagMaster's own security between tag and reader
Access Password is a security mode with password authentication

AES-128 is a security mode with privacy and authentication for tags based on NXP UCODE DNA

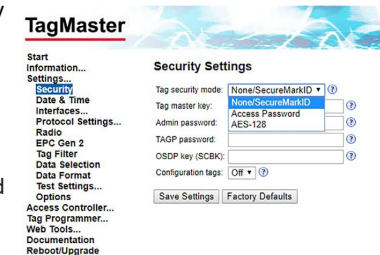

SOFTWARE CONFIGURATION

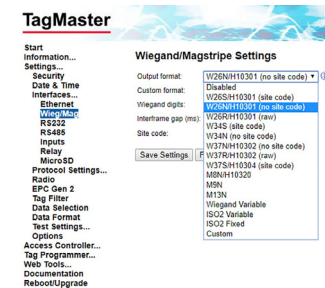

The available Wiegand settings from the TagMaster XT web interface.